

# Skills USA

## Industrial Motor Controls

### SCOPE OF THE CONTEST

The contestants will demonstrate their knowledge and ability of industrial motor controls.  
*(Total time of tasks will be the main deciding factor in a tie.)*

### TASKS:

- 1.) Low Level Alarm Silence Circuit (1.5 hrs.)
- 2.) Written Test (30 min)

### EQUIPMENT/MATERIALS:

#### 1.) Supplied by contestants:

-Diagonal pliers, side cutters, claw hammer, needle nose pliers, torpedo level, assorted flat blade and Phillips screwdrivers, measuring tape, wire strippers, knife, scratch awl, volt/Ohm meter and National Electrical Code book (most current edition)

#### 2.) Supplied by Rosedale Tech:

-All electrical components necessary to complete tasks.

### SAFETY REQUIREMENTS

- 1.) Contestants must have knowledge of operational and safety procedures when using tools and equipment.
- 2.) All standard shop and safety procedures must be observed.
- 3.) During shop completion, all contestants must wear safety glasses or goggles and work shoes.

# Task # 1

## Low level Alarm Silence Circuit

You will have 1.5 hrs. to complete this task.

### Directions:

Install and wire all components to the specifications indicated on the ladder diagram below.

All necessary materials will be provided in the designated work area for this task. Notify the judge when you have completed the task.

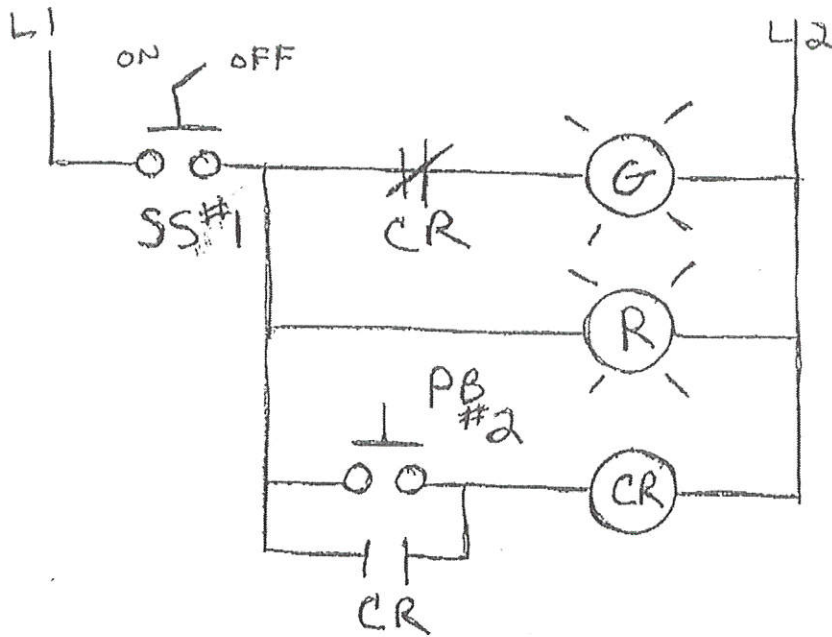

ALARM SILENCE CIRCUIT

Contestant Number: \_\_\_\_\_

Time Started: \_\_\_\_\_

Time Ended: \_\_\_\_\_

Total time on task: \_\_\_\_\_

Judges Initials: \_\_\_\_\_

**Skills USA**  
**Industrial Motor Controls - Tally Sheet**

Contestant Number: \_\_\_\_\_

Items Evaluated	Possible Points	Task # 1
Procedure	25	
Accuracy	25	
Quality/Appearance	15	
Speed	15	
Tool/Equipment Usage	10	
Safety Practices	10	
<b>Total</b>	<b>100</b>	
Judges Initials		

Task	Total Points
Task # 1 (100pts)	
Written Test (50pts)	
<b>Total</b>	

Judges Initials: \_\_\_\_\_